



QUINNmerriott

RADIAVECTOR RADIATORS TECHNICAL INFORMATION



CONTENTS

Specification	2
Radiavectors Introduction & Overview	3
K22 – Heat emissions at 70, 140, 210 & 280mm high	4
K34 – Heat emissions at 70, 140, 210 & 280mm high	5
K46 – Heat emissions at 70, 140, 210 & 280mm high	6
K58 – Heat emissions at 70, 140, 210 & 280mm high	7
Applications	8
Bracket & feet details	10
Resistance diagrams	13
Resistance	14
Correction factors	15-16
Connection details	17-18
How to Order	19

Specification

Paint

Quinn Merriott uses a painting process developed for the automobile industry. In pre-treatment, the radiavectors go through a series of washes which degrease the steel. An iron phosphaterinse passivates the surface prior to painting.

The primer coat is applied by immersion in an electrophoretic bath to give total cover of the bare steel and maximum corrosion protection. This coat is baked at 200°C. The durable topcoat (epoxy polyester powder) is electrostatically applied and stove enamel baked at 200°C. The process is monitored to ensure continuous achievement of optimum adhesion, opacity and gloss levels.

Colour

Our standard finish is semi-gloss RAL 9016 (White) in epoxy polyester powder. An extensive range of other RAL colours are available, at a surcharge, on request.

Sizing & Heat Emissions

Quinn Merriott radiavectors offer emissions ranging from 346 watts to 2562 watts per metre at $\Delta T 50^{\circ}\text{C}$. Comprehensive sizing and emission charts are included in this catalogue.

Height

The height of the radiavector increases in increments of 70mm, from a minimum of 70mm through to 280mm, from 2-panel to 5-panel deep radiavectors.

Length

The radiavector length always relates to the overall front panel length, and increases in increments of 100mm, from a minimum of 500 mm through to 3000 mm. When the radiavector must span exact distances such as gaps between mullions or where it must match existing standpipe centres, the length can be specified in increments of 25mm.

Dimensional Tolerances

Dimensional tolerances are in accordance with **EN442**.

Materials

Quinn Merriott radiavectors are manufactured from flat steel tube, 70mm x 11mm, with a standard thickness of 1.25mm. Other thicknesses are available on request.

Operating Pressures

The standard test pressure is 5.2 bar giving a maximum operating pressure of 4.0 Bar.

Other Operating Pressures

For details on other operating pressures please contact the Quinn Merriott Sales Office.

Connections

Standard connections are 4 x 1/2" (15mm) BSP connections. These can be used as BOE or TBOE connection configurations. Other connections available include:

- TBSE connections
- ventil connections
- 3/4" (20mm) connections.

Brackets and Feet

The radiavector is supplied with a foot at 140mm high, as standard. A surface mounting bracket is also available. For full details of brackets and feet, please turn to pages 10 (K22 folded foot & cantilever bkt), 11 (K34, K46, K58 folded foot & cantilever bkt) and 12 (Folded feet & Boxsection feet)

Grilles

All Quinn Merriott radiavectors are supplied as standard without top grilles but grilles can be supplied at an extra cost.

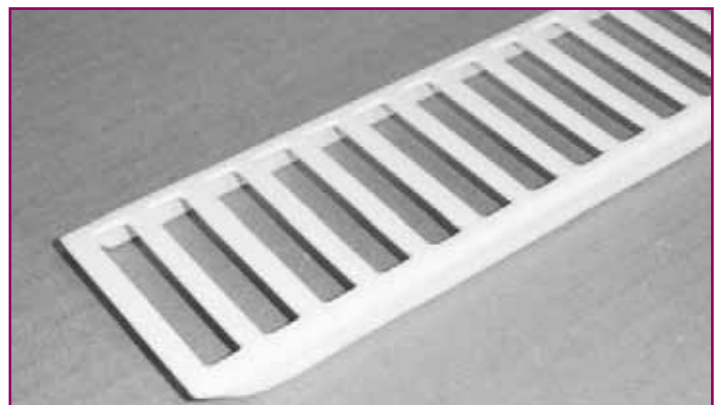

Note:

Grilles must be confirmed at time of order.

Radiavectors Introduction & Overview

K22

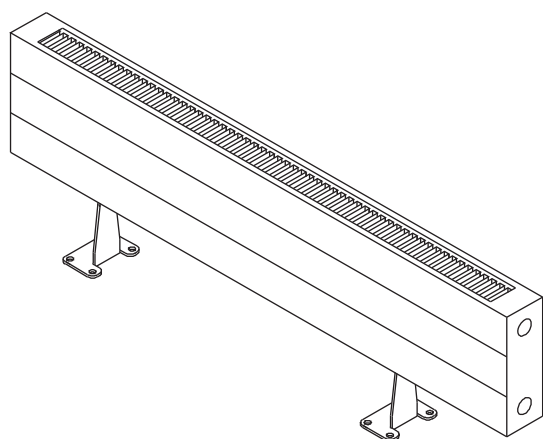

Model	no of panels	no of fins	Product type
K22	2	1	2 Panel

K34

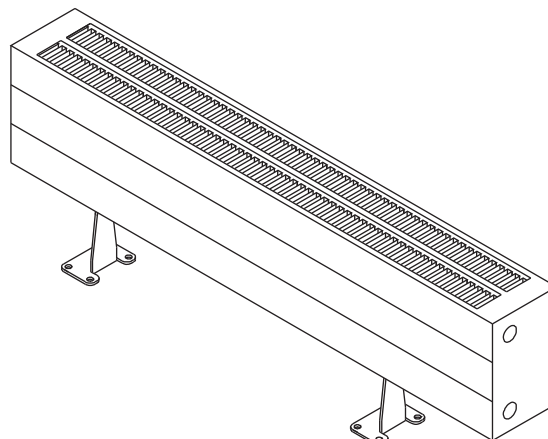

Model	no of panels	no of fins	Product type
K34	3	2	3 Panel

K46

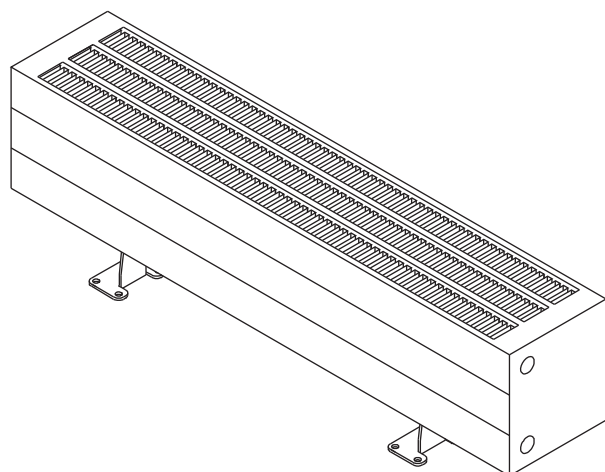

Model	no of panels	no of fins	Product type
K46	4	3	4 Panel

K58

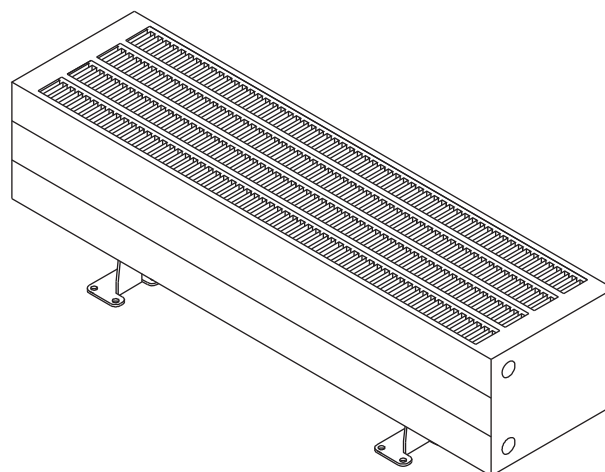

Model	no of panels	no of fins	Product type
K58	5	4	5 Panel

Height: ranges from 70mm to 280mm in increments of 70mm.

Length: ranges from 500mm to 3000mm in increments of 100mm. Other lengths are available on request.

Heat Emissions - K22

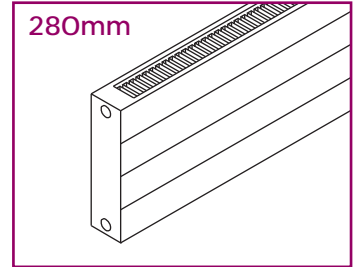
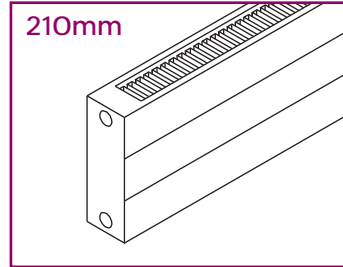
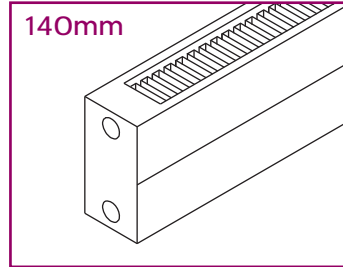
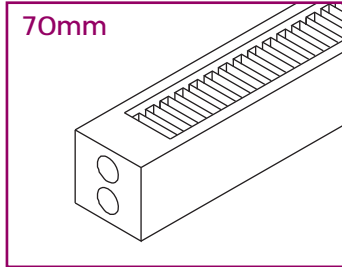

Height
Depth (mm)
Dry Weight (kg/m)
Water Content (l/m)
Surface Area (m2/m)

70mm
72
5.5
1.1
1.07

140mm
72
11
2.3
2.26

210mm
72
16.7
3.4
3.45

280mm
72
22.3
4.6
4.64

Length
mm
500
600
700
800
900
1000
1100
1200
1300
1400
1500
1600
1700
1800
1900
2000
2100
2200
2300
2400
2500
2600
2700
2800
2900
3000

Output (Watts)	
$\Delta T50$	$\Delta T56$
173	199
208	239
242	279
277	318
311	358
346	398
381	438
415	478
450	517
484	557
519	597
554	637
588	677
623	716
657	756
692	796
727	836
761	876
796	915
830	955
865	995
900	1035
934	1075
969	1114
1003	1154
1038	1194

Output (Watts)	
$\Delta T50$	$\Delta T56$
277	320
332	384
388	448
443	512
499	576
554	640
609	704
665	768
720	832
776	896
831	960
886	1024
942	1088
997	1152
1053	1216
1108	1280
1163	1344
1219	1408
1274	1472
1330	1536
1385	1600
1440	1664
1496	1728
1551	1792
1607	1856
1662	1920

Output (Watts)	
$\Delta T50$	$\Delta T56$
347	403
416	483
486	564
555	644
625	725
694	805
763	886
833	966
902	1047
972	1127
1041	1208
1110	1288
1180	1369
1249	1449
1319	1530
1388	1610
1457	1691
1527	1771
1596	1852
1666	1932
1735	2013
1804	2093
1874	2174
1943	2254
2013	2335
2082	2415

Output (Watts)	
$\Delta T50$	$\Delta T56$
416	484
499	581
582	678
666	774
749	871
832	968
915	1065
998	1162
1082	1258
1165	1355
1248	1452
1331	1549
1414	1646
1498	1742
1581	1839
1664	1936
1747	2033
1830	2130
1914	2226
1997	2323
2080	2420
2163	2517
2246	2614
2330	2710
2413	2807
2496	2904

Heat Emissions - K34

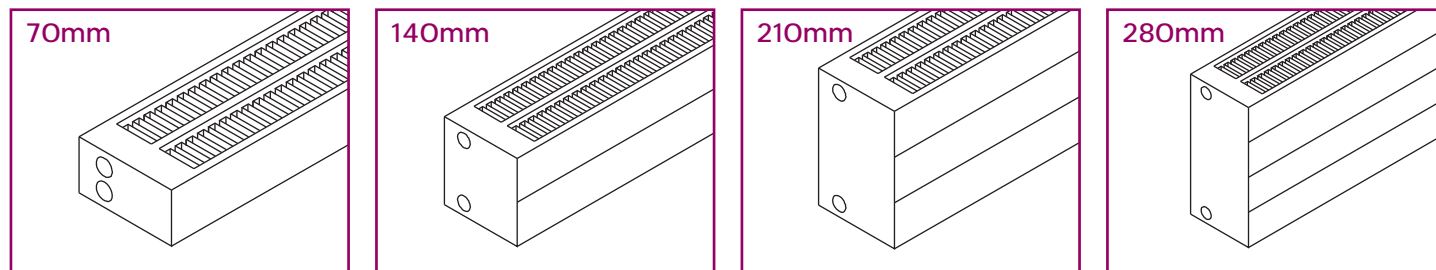

Height
Depth (mm)
Dry Weight (kg/m)
Water Content (l/m)
Surface Area (m2/m)

70mm
133
9.1
1.7
1.97

140mm
133
18.7
3.4
4.19

210mm
133
28.3
5.3
6.41

280mm
133
37.9
6.9
8.63

Length
mm
500
600
700
800
900
1000
1100
1200
1300
1400
1500
1600
1700
1800
1900
2000
2100
2200
2300
2400
2500
2600
2700
2800
2900
3000

Output (Watts)	
$\Delta T50$	$\Delta T56$
289	333
347	399
405	466
462	532
520	599
578	665
636	732
694	798
751	865
809	931
867	998
925	1064
983	1131
1040	1197
1098	1264
1156	1330
1214	1397
1272	1463
1329	1530
1387	1596
1445	1663
1503	1729
1561	1796
1618	1862
1676	1929
1734	1995

Output (Watts)	
$\Delta T50$	$\Delta T56$
445	517
534	620
623	724
712	827
801	931
890	1034
979	1137
1068	1241
1157	1344
1246	1448
1335	1551
1424	1654
1513	1758
1602	1861
1691	1965
1780	2068
1869	2171
1958	2275
2047	2378
2136	2482
2225	2585
2314	2688
2403	2792
2492	2895
2581	2999
2670	3102

Output (Watts)	
$\Delta T50$	$\Delta T56$
563	656
676	787
788	918
901	1049
1013	1180
1126	1311
1239	1442
1351	1573
1464	1704
1576	1835
1689	1967
1802	2098
1914	2229
2027	2360
2139	2491
2252	2622
2365	2753
2477	2884
2590	3015
2702	3146
2815	3278
2928	3409
3040	3540
3153	3671
3265	3802
3378	3933

Output (Watts)	
$\Delta T50$	$\Delta T56$
681	794
817	953
953	1112
1089	1270
1225	1429
1361	1588
1497	1747
1633	1906
1769	2064
1905	2223
2042	2382
2178	2541
2314	2700
2450	2858
2586	3017
2722	3176
2858	3335
2994	3494
3130	3652
3266	3811
3403	3970
3539	4129
3675	4288
3811	4446
3947	4605
4083	4764

Heat Emissions - K46

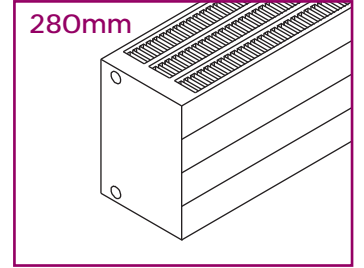
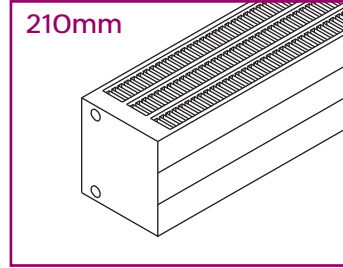
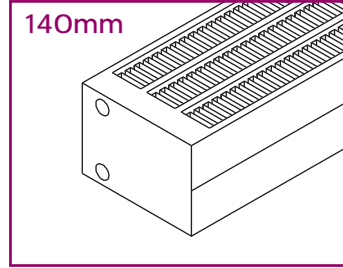
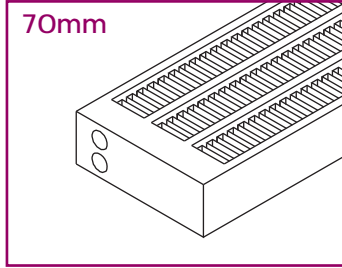

Height
Depth (mm)
Dry Weight (kg/m)
Water Content (l/m)
Surface Area (m2/m)

70mm
194
12.6
2.3
2.88

140mm
194
25.8
4.6
6.12

210mm
194
39.7
6.9
9.37

280mm
194
53.6
9.2
12.62

Length
mm
500
600
700
800
900
1000
1100
1200
1300
1400
1500
1600
1700
1800
1900
2000
2100
2200
2300
2400
2500
2600
2700
2800
2900
3000

Output (Watts)	
$\Delta T50$	$\Delta T56$
406	468
487	561
568	655
650	748
731	842
812	935
893	1029
974	1122
1056	1216
1137	1309
1218	1403
1299	1496
1380	1590
1462	1683
1543	1777
1624	1870
1705	2057
1786	1629
1868	2151
1949	2244
2030	2338
2111	2431
2192	2525
2274	2618
2355	2712
2436	2805

Output (Watts)	
$\Delta T50$	$\Delta T56$
631	733
757	880
883	1026
1010	1173
1136	1319
1262	1466
1388	1613
1514	1759
1641	1906
1767	2052
1893	2199
2019	2346
2145	2492
2272	2639
2398	2785
2524	2932
2776	3225
2565	2973
2903	3372
3029	3518
3155	3665
3281	3812
3407	3958
3534	4105
3660	4251
3786	4398

Output (Watts)	
$\Delta T50$	$\Delta T56$
802	934
962	1121
1122	1308
1282	1494
1443	1681
1603	1868
1763	2055
1924	2242
2084	2428
2244	2615
2405	2802
2565	2989
2725	3176
2885	3362
3046	3549
3206	3736
3527	4110
3487	4041
3687	4296
3847	4483
4008	4670
4168	4857
4328	5044
4488	5230
4649	5417
4809	5604

Output (Watts)	
$\Delta T50$	$\Delta T56$
971	1135
1165	1362
1359	1589
1553	1816
1747	2043
1941	2270
2135	2497
2329	2724
2523	2951
2717	3178
2912	3405
3106	3632
3300	3859
3494	4086
3688	4313
3882	4540
4270	4994
4191	4857
4464	5221
4658	5448
4853	5675
5047	5902
5241	6129
5435	6356
5629	6583
5823	6810

Heat Emissions - K58

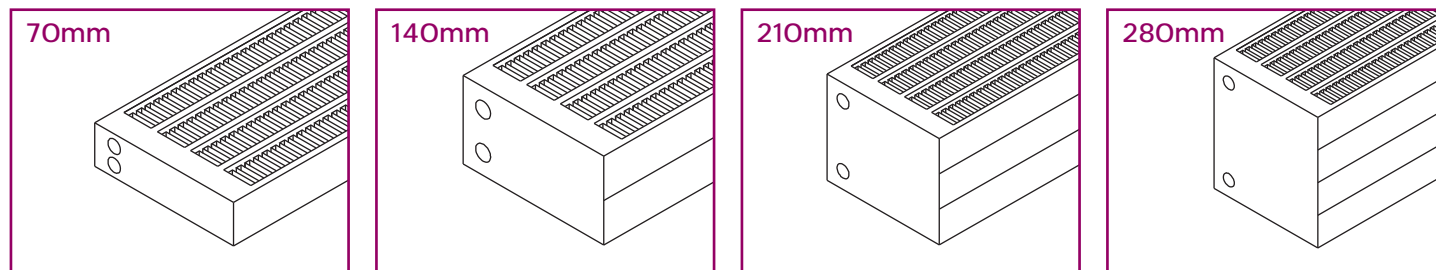

Height
Depth (mm)
Dry Weight (kg/m)
Water Content (l/m)
Surface Area (m2/m)

70mm
255
16.1
2.9
3.78

140mm
255
33.7
5.7
8.06

210mm
255
50.9
8.6
12.33

280mm
255
69
11.5
16.61

Length
mm
500
600
700
800
900
1000
1100
1200
1300
1400
1500
1600
1700
1800
1900
2000
2100
2200
2300
2400
2500
2600
2700
2800
2900
3000

Output (Watts)	
$\Delta T50$	$\Delta T56$
514	593
617	712
720	830
822	949
925	1067
1028	1186
1131	1305
1234	1423
1336	1542
1439	1660
1542	1779
1645	1898
1748	2016
1850	2135
1953	2253
2056	2372
2159	2491
2262	2609
2364	2728
2467	2846
2570	2965
2673	3084
2776	3202
2878	3321
2981	3439
3084	3558

Output (Watts)	
$\Delta T50$	$\Delta T56$
821	953
985	1144
1149	1334
1313	1525
1477	1715
1641	1906
1805	2097
1969	2287
2133	2478
2297	2668
2462	2859
2626	3050
2790	3240
2954	3431
3118	3621
3282	3812
3446	4003
3610	4193
3774	4384
3938	4574
4103	4765
4267	4956
4431	5146
4595	5337
4759	5527
4923	5718

Output (Watts)	
$\Delta T50$	$\Delta T56$
1053	1228
1263	1474
1474	1719
1684	1965
1895	2210
2105	2456
2316	2702
2526	2947
2737	3193
2947	3438
3158	3684
3368	3930
3579	4175
3789	4421
4000	4666
4210	4912
4421	5158
4631	5403
4842	5649
5052	5894
5263	6140
5473	6386
5684	6631
5894	6877
6105	7122
6315	7368

Output (Watts)	
$\Delta T50$	$\Delta T56$
1281	1502
1537	1802
1793	2102
2050	2402
2306	2703
2562	3003
2818	3303
3074	3604
3331	3904
3587	4204
3843	4505
4099	4805
4355	5105
4612	5405
4868	5706
5124	6006
5380	6306
5636	6607
5893	6907
6149	7207
6405	7508
6661	7808
6917	8108
7174	8408
7430	8709
7686	9009

Applications

K22

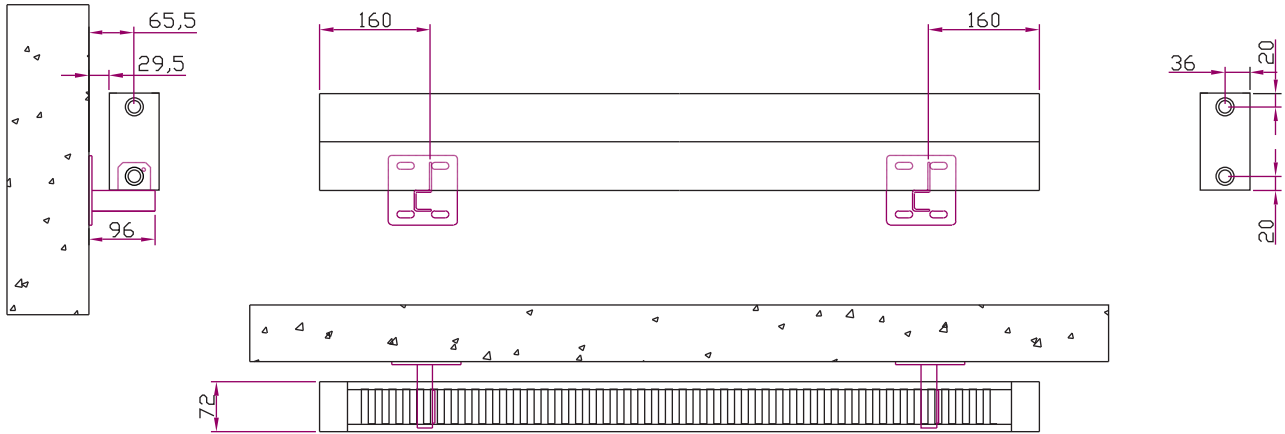

K34

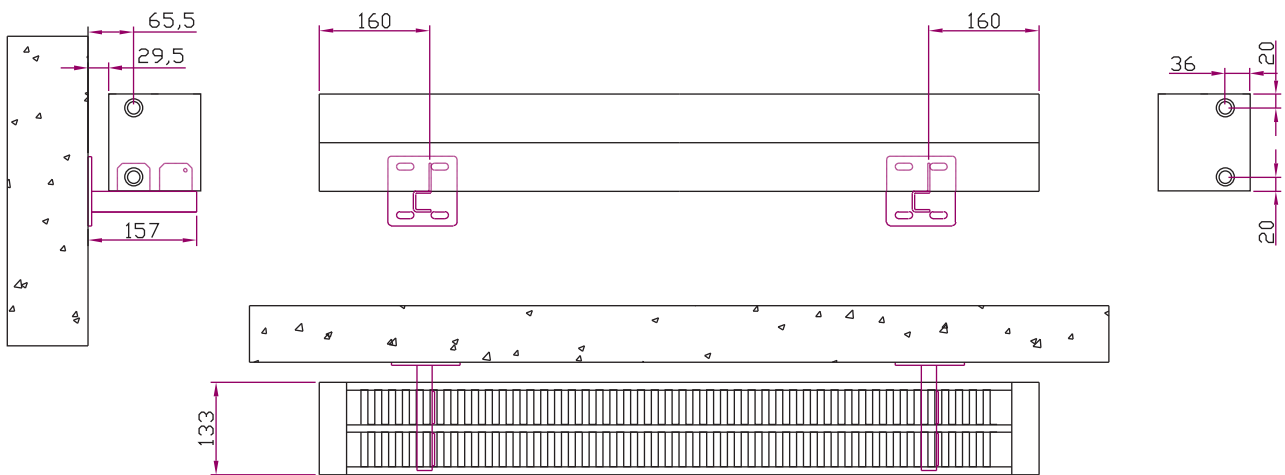

Note: All dimensions shown are the same when using cantilever brackets or radiavector feet, see pages 10 (K22) and 11 (K34, K46, K58) for details.

All dimensions are in millimetres

Applications

K46

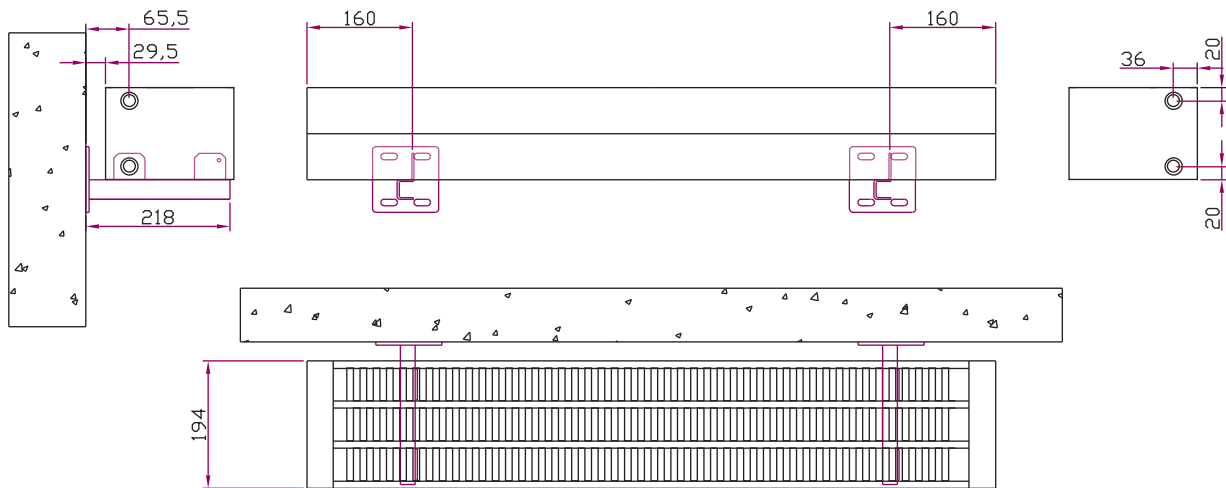

K58

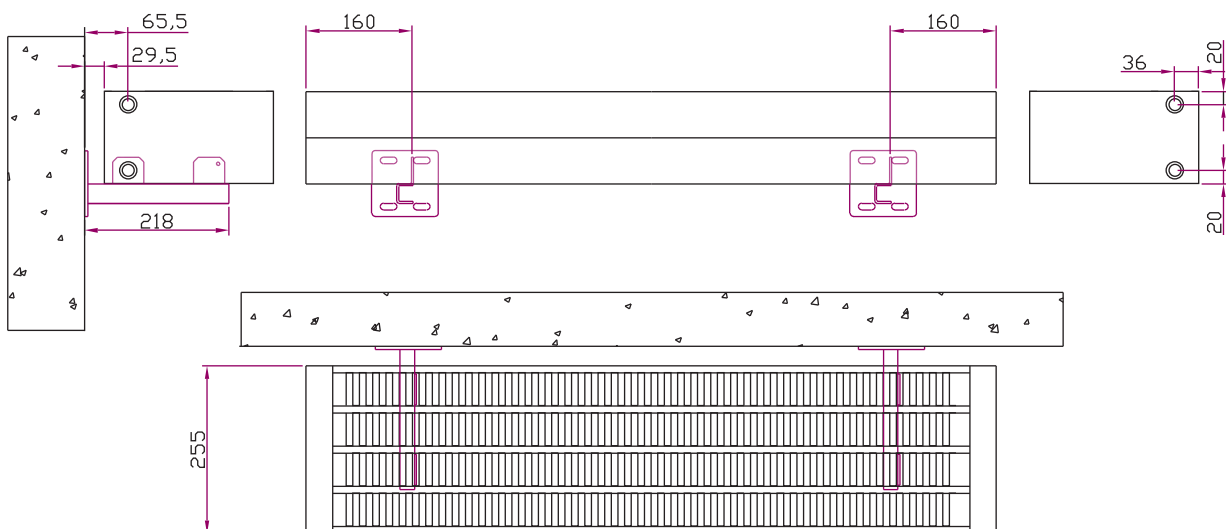

Note: All dimensions shown are the same when using cantilever brackets or radiavector feet, see pages 10 (K22) and 11 (K34, K46, K58) for details.

All dimensions are in millimetres

Bracket and Foot Details

K22 Cantilever Bracket

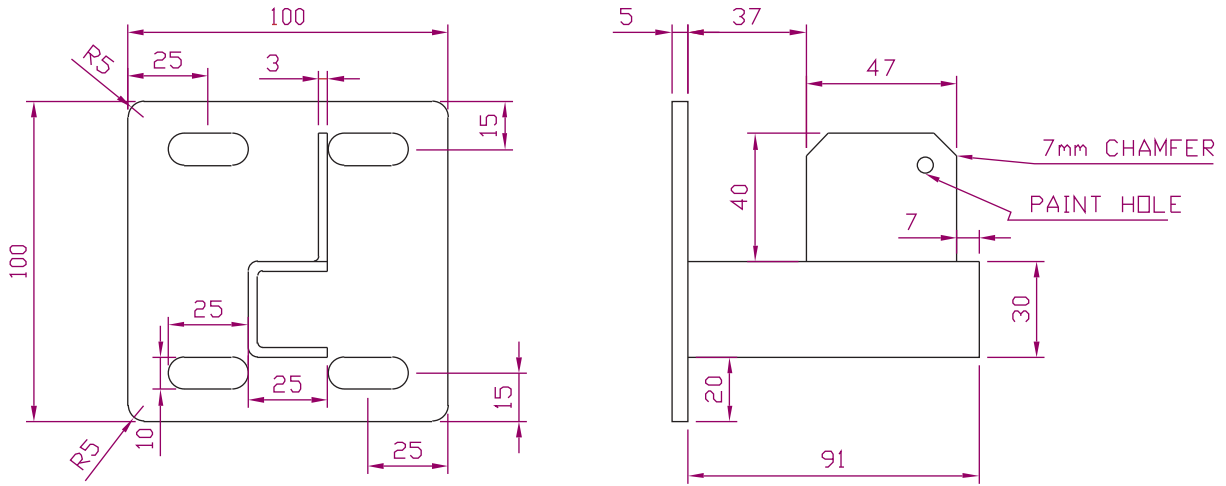

order number PP-B014

K22 Radiavector Foot

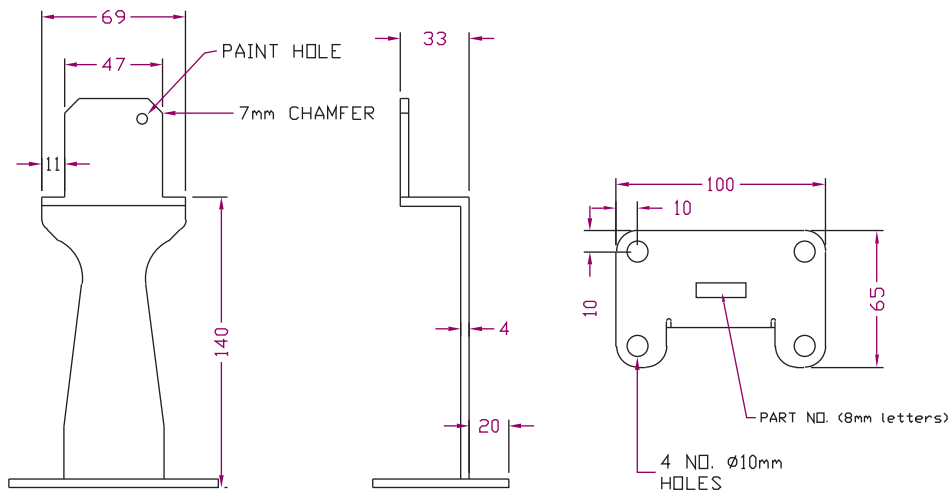

NOTES :
1. DIMENSIONS IN MM.
2. MATERIAL 4MM

order number PP-F011

All dimensions are in millimetres

Bracket and Foot Details

Radiavector Foot

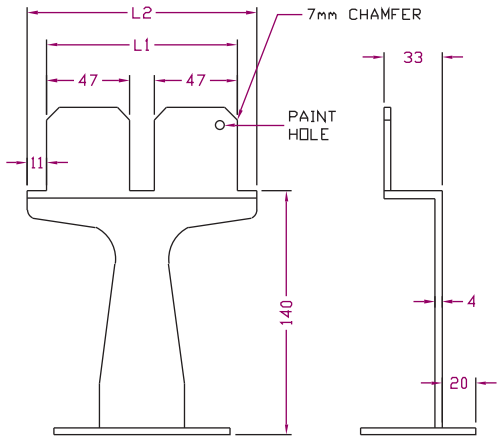

NOTES :
 1. DIMENSIONS IN MM
 2. MATERIAL 4MM
 3. L1 AND L2 DIMENSIONS AS PER TABLE

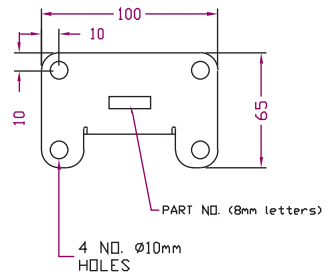

Radiavector
K34, 58
K46

L1	L2
108	130
168	190

order number PP-F012

Cantilever Bracket

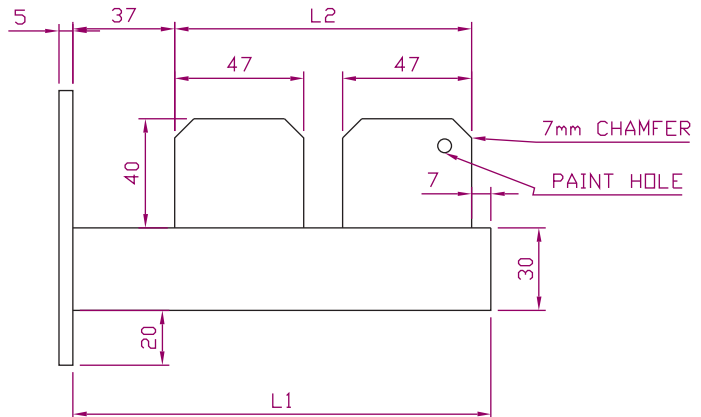
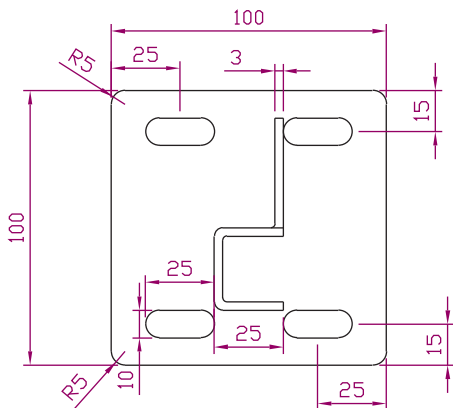

Radiavector
K34
K46, 58

L1	L2
152	108
212	168

order number PP-B015

Foot Details

(As products are subject to continued research to improve design and performance, we reserve the right to alter specifications without notice)

Folded Feet

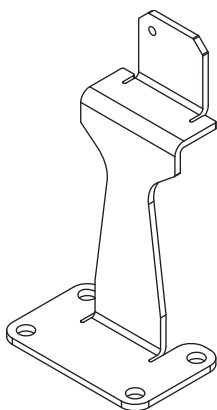

PP-F011

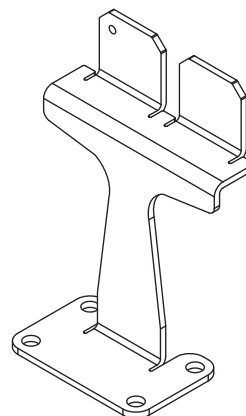

PP-F012

Box Feet

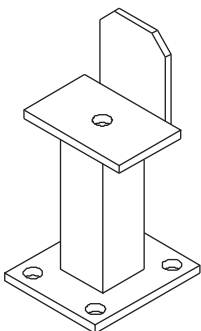

PP-F056

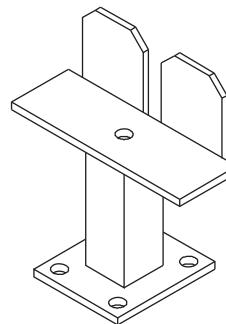

PP-F057

Both feet PP-F011 & PP-F012 are folded loose feet.

Both feet PP-F056 & PP-F057 are loose box section feet.

The dimensions are the same for the box section foot as for the folded foot.

Please quote the code of the foot you require at the order stage

Please note: For all loose feet over 140mm high we recommend the box section type rather than the folded type.

For all our feet we recommend the use of proper floor securing bolts

E.g. Rawl Bolts M8 upwards, Thru' Bolts M8 upwards.

Resistance Diagrams

K22

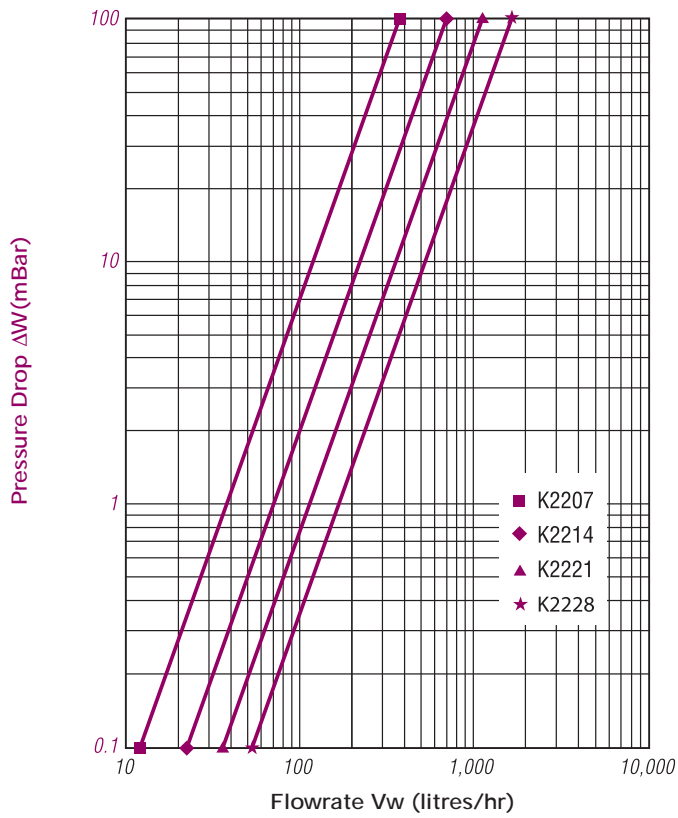

K34

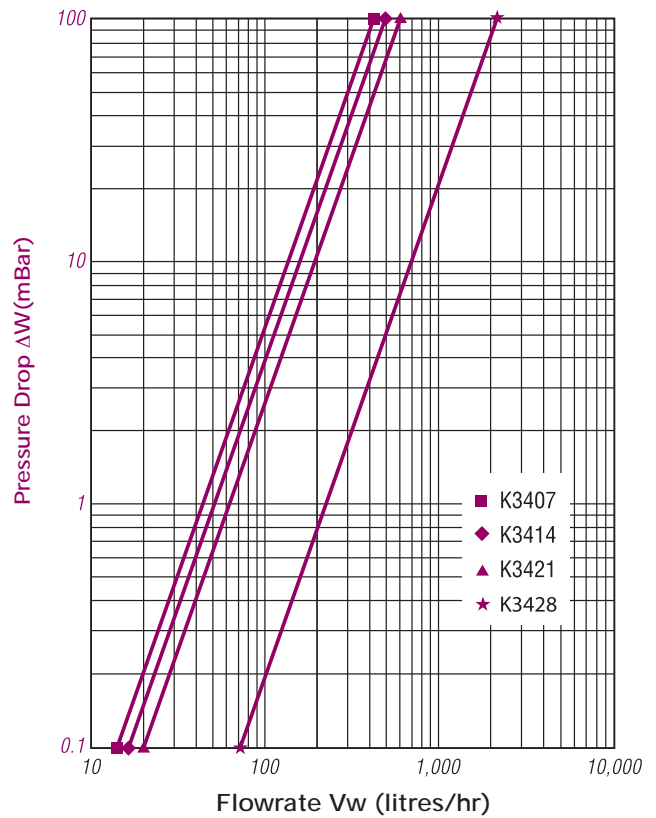

K46

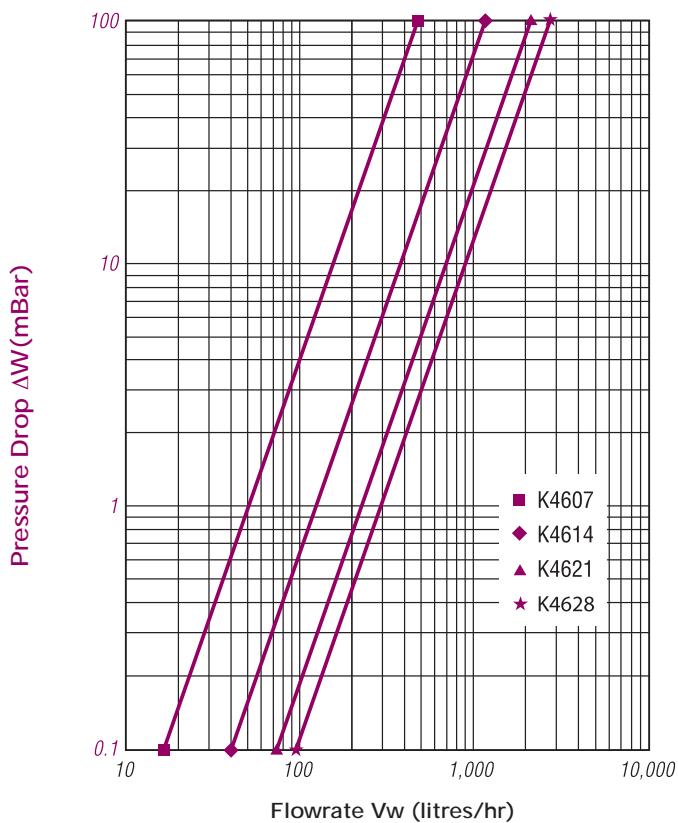

K58

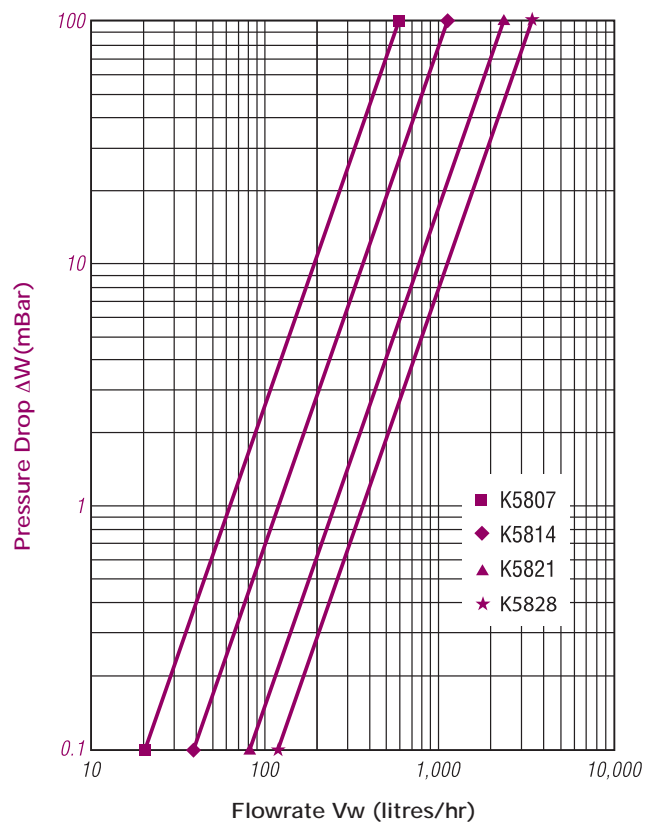

Resistance

How to calculate the Resistance of a Radiavector.

The following is how to find the resistance of a radiavector type K58 2000mm long X 140mm high:

First, establish what the output of the radiavector is.

This is found in the catalogue. (For this particular example please see page 7).

Output from the Catalogue is 3812 Watts

In this example the system is operating at $\Delta T 56^{\circ}\text{C}$ (Flow @ 82°C , Return 71°C).

(If the output is for a $\Delta T^{\circ}\text{C}$ other than what is indicated in the emission tables ($\Delta T 50^{\circ}\text{C}$ or $\Delta T 56^{\circ}\text{C}$) please use the correction factor tables indicated to get the corrected output.)

C is the Specific Heat Constant (always $4187 \text{ J/Kg}^{\circ}\text{C}$)

Calculate the flow rate as follows:

$$Q = \quad (\text{m}) \quad \times \quad (\text{C}) \quad \times \quad (\Delta T)$$

$$\text{Output} = (\text{Flow Rate}) \quad (\text{Constant}) \quad (\text{Difference between flow and return temperature})$$

$$\text{Watts} = (\text{l/s}) \quad (\text{J/Kg}^{\circ}\text{C}) \quad (^{\circ}\text{C})$$

$$3812 = (\text{m}) \quad (4187) \quad (11)$$

Therefore

$$m = \quad 3812 / ((4187) \times (11))$$

$$m = \quad 0.082767006 \text{ Litres per Second (l/s) multiply by 3600 to convert to litres per hour}$$

$$m = \quad 298.0 \text{ litres per hour (l/hr)}$$

Now, look up the Resistance Diagram:

Reading from the chart this gives a value of 6.5mBar or 0.65Kpa
(For a K58 140mm read from the line K5814)

Depending on the height of the radiator, utilise one of the following lines of the appropriate chart:

K2207 is a K22 radiavector 70mm high

K3414 is a K34 radiavector 140mm high

K4621 is a K46 radiavector 210mm high

K5828 is a K58 radiavector 280mm high

Correction Factors

Emissions at two separate Delta T°Cs (ΔT°Cs) are provided in the Heat Emission Charts in this catalogue.

Listed below are the correction factors needed to calculate the emission at other Delta Ts (ΔTs) between 30° and 80°C. This is done by correcting your heat emission with the appropriate correction factor selected from the table below.

Example:

Say, required room temperature = 21°C, flow temperature = 86°C, return temperature = 72°C

How is the emission found?

Solution:

Mean Water Temperature = (T flow + T return)/2 = (86 + 72)/2 = 79°C

DeltaT = Mean Water Temp - Required Room Temp = 79 - 21 = 58°C

From the tables for K34, the emission is 1.215 times the emission stated at ΔT 50°C or 1.047 times the emission stated at ΔT 56°C

K22

ΔT(°C)P	Based on	
	ΔT50	ΔT56
30	0.517	0.447
31	0.540	0.466
32	0.562	0.486
33	0.585	0.506
34	0.608	0.525
35	0.631	0.545
36	0.655	0.566
37	0.678	0.586
38	0.702	0.606
39	0.726	0.627
40	0.750	0.648
41	0.774	0.669
42	0.799	0.690
43	0.823	0.711
44	0.848	0.733
45	0.873	0.754
46	0.898	0.776
47	0.923	0.798
48	0.949	0.820
49	0.974	0.842
50	1.000	0.864
51	1.026	0.886
52	1.052	0.909
53	1.078	0.931
54	1.104	0.954
55	1.131	0.977

K34

ΔT(°C)P	Based on	
	ΔT50	ΔT56
56	1.157	1.000
57	1.184	1.023
58	1.211	1.046
59	1.238	1.070
60	1.265	1.093
61	1.292	1.117
62	1.320	1.140
63	1.347	1.164
64	1.375	1.188
65	1.403	1.212
66	1.431	1.236
67	1.459	1.260
68	1.487	1.285
69	1.515	1.309
70	1.544	1.334
71	1.572	1.358
72	1.601	1.383
73	1.629	1.408
74	1.658	1.433
75	1.687	1.458
76	1.716	1.483
77	1.745	1.508
78	1.775	1.533
79	1.804	1.559
80	1.834	1.584

ΔT(°C)P	Based on	
	ΔT50	ΔT56
30	0.512	0.442
31	0.535	0.461
32	0.557	0.480
33	0.580	0.500
34	0.603	0.520
35	0.627	0.540
36	0.650	0.561
37	0.674	0.581
38	0.698	0.602
39	0.722	0.623
40	0.747	0.644
41	0.771	0.665
42	0.796	0.687
43	0.821	0.708
44	0.846	0.729
45	0.871	0.751
46	0.897	0.773
47	0.922	0.795
48	0.948	0.817
49	0.974	0.840
50	1.000	0.862
51	1.027	0.885
52	1.053	0.908
53	1.080	0.930
54	1.106	0.954
55	1.133	0.977

ΔT(°C)P	Based on	
	ΔT50	ΔT56
56	1.160	1.000
57	1.187	1.024
58	1.215	1.047
59	1.242	1.071
60	1.270	1.095
61	1.298	1.119
62	1.326	1.143
63	1.354	1.167
64	1.382	1.191
65	1.410	1.216
66	1.439	1.240
67	1.467	1.265
68	1.496	1.270
69	1.525	1.315
70	1.554	1.340
71	1.583	1.365
72	1.612	1.390
73	1.642	1.415
74	1.671	1.441
75	1.701	1.467
76	1.731	1.492
77	1.761	1.518
78	1.791	1.544
79	1.821	1.570
80	1.851	1.596

Correction Factors

K46

$\Delta T(^{\circ}C)P$	Based on	
	$\Delta T50$	$\Delta T56$
30	0.507	0.436
31	0.530	0.455
32	0.552	0.475
33	0.575	0.495
34	0.598	0.515
35	0.622	0.535
36	0.646	0.556
37	0.670	0.576
38	0.694	0.597
39	0.719	0.618
40	0.743	0.639
41	0.768	0.661
42	0.793	0.682
43	0.818	0.704
44	0.844	0.726
45	0.869	0.748
46	0.895	0.770
47	0.921	0.792
48	0.947	0.815
49	0.974	0.837
50	1.000	0.860
51	1.027	0.883
52	1.054	0.906
53	1.081	0.929
54	1.108	0.953
55	1.135	0.976

K58

$\Delta T(^{\circ}C)P$	Based on	
	$\Delta T50$	$\Delta T56$
56	1.163	1.000
57	1.190	1.024
58	1.218	1.048
59	1.246	1.072
60	1.275	1.096
61	1.303	1.121
62	1.331	1.145
63	1.360	1.170
64	1.389	1.194
65	1.418	1.219
66	1.447	1.244
67	1.476	1.270
68	1.505	1.295
69	1.535	1.320
70	1.564	1.346
71	1.594	1.371
72	1.624	1.397
73	1.654	1.423
74	1.684	1.449
75	1.715	1.475
76	1.745	1.501
77	1.776	1.527
78	1.807	1.554
79	1.837	1.580
80	1.868	1.607

$\Delta T(^{\circ}C)P$	Based on	
	$\Delta T50$	$\Delta T56$
30	0.504	0.433
31	0.527	0.453
32	0.550	0.472
33	0.573	0.492
34	0.596	0.512
35	0.620	0.533
36	0.644	0.553
37	0.668	0.574
38	0.692	0.595
39	0.717	0.616
40	0.742	0.637
41	0.767	0.659
42	0.792	0.680
43	0.817	0.702
44	0.843	0.724
45	0.868	0.746
46	0.894	0.768
47	0.920	0.791
48	0.947	0.813
49	0.973	0.836
50	1.000	0.859
51	1.027	0.882
52	1.054	0.906
53	1.081	0.929
54	1.109	0.952
55	1.136	0.976

$\Delta T(^{\circ}C)P$	Based on	
	$\Delta T50$	$\Delta T56$
56	1.164	1.000
57	1.192	1.024
58	1.220	1.048
59	1.248	1.072
60	1.277	1.097
61	1.305	1.121
62	1.334	1.146
63	1.363	1.171
64	1.392	1.196
65	1.421	1.221
66	1.451	1.246
67	1.480	1.272
68	1.510	1.297
69	1.540	1.323
70	1.570	1.349
71	1.600	1.374
72	1.630	1.400
73	1.661	1.427
74	1.691	1.453
75	1.722	1.479
76	1.753	1.506
77	1.784	1.532
78	1.815	1.559
79	1.846	1.586
80	1.877	1.613

Connection Details

Standard connections

Bottom Opposite Ends connections/Top & Bottom Opposite End connections

A, B, C, D, E, F denote the connection positions. The standard connection configuration on the radiavector is 4 x 1/2" (15mm) BSP connections at ABCD.

These can be used as Bottom Opposite End connections or Top & Bottom Opposite End connections.

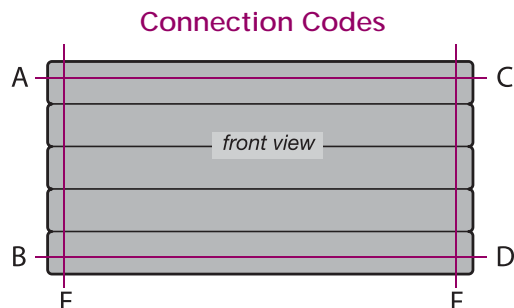

Other connection configurations

Top & Bottom Same End connections

Top & Bottom Same End connections must be specified at the time of order and cannot be used on a 4-connection radiavector.

Vertical connections

EF connections are available on all models of radiavector. Other vertical connections available on request

Special connection configurations

Ventil connections

Ventil connection radiavectors can be used in situations where low profile pipework is required.

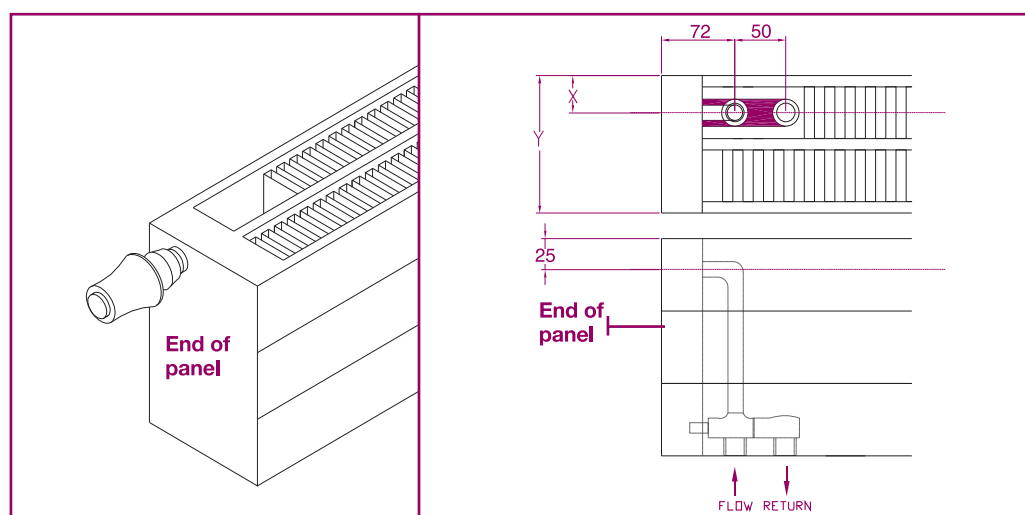

Type	Y	X
VK22	72mm	36mm
VK34	133mm	36mm
VK46	194mm	36mm
VK58	255mm	36mm

Y = Width of Radiator

X = Distance from the back panel to the centre of the connection

Note: Distance from the end of the panel to the centre of the flow connection is 72mm for all models

Connection Details

Connection Centre Details

Rad Type	Connection Arrangement See Page 17	Stub to Stub Dim.	Distance from Wall (Connection)	Distance from Wall	
				Rad Width	Front Face To Wall
K22	"A, B, C, D"	L	66	72	102
K22	"E, F"	L-44	66	72	102
K34	"A, B, C, D"	L	66	133	163
K34	"E, F"	L-44	66	133	163
K46	"A, B, C, D"	L	66	194	224
K46	"E, F"	L-44	66	194	224
K58	"A, B, C, D"	L	66	255	285
K58	"E, F"	L-44	66	255	285

L = The overall length of the radiavector

All values are in mm

For ABCD connections all connections are the same distance from the top or the bottom of the radiavector. It is 20 mm to the centre of the connection from the top or to the bottom edge of the radiavector. Both connections are the same distance from the wall.

How to Order

How To Order A Radiavector

Standard		Ventile
K22/O	Code	VK22/O
K34/O	Code	VK34/O
K46/O	Code	VK46/O
K58/O	Code	VK58/O

E.g Standard

To order a K34 1000mm long 280mm high K34/O 1000 x 280mm
Then give connection details required ABCD etc

E.g. Ventil

To order a VK46 1500mm long 140mm high VK46/O 1500 x 140mm
Then give what side you require the ventile connection to be on LH or RH.

Head Office Quinn Radiators

Derrylin, Co. Fermanagh, Northern Ireland, BT92 9AU

Tel : +44 (0) 28 6774 8888

Fax : +44 (0) 28 6774 8107

Email : sales@quinn-merriott.com

Web : www.quinn-merriott.com

Manufacturing Facility

Quinn Radiators, Imperial Park, Newport, Gwent NP10 8ZY

Tel : +44 (0) 1633 657 000

Fax : +44 (0) 1633 657 084

Irish Enquires

Quotes:

Tel : +44 (0) 28 6774 2606

Fax: +353 (0) 49 9525231

Orders:

Tel : +44 (0) 28 6774 2503

Fax: +353 (0) 49 9525231

UK Enquires

Quotes:

Tel : +44 (0) 28 6774 2549

Fax: +353 (0) 49 9525231

Orders:

Tel : +44 (0) 28 6774 2182

+44 (0) 1942 262466

Fax: +353 (0) 49 9525231

+44 (0) 1942 260684

Notes



	
AERATED THERMAL BLOCKS	
	
CEMENT	
	
CONCRETE ROOFTILES	
	
QUINN THERM (PIR)	
	
QUINN LITE PAC	
	
PRESTRESSED	
	
QUARRY	
	
TARMAC	
	
ENERGY	
	
FINANCIAL SERVICES	
	
GLASS	
	
HOTELS	
	
PACKAGING	
	
PLASTICS	
	
PROPERTY	
	
RADIATORS	

QUINN GROUP

Derryllin, County Fermanagh,
Northern Ireland, BT92 9AU.

Freephone: 0800 389980
f: +44 (0) 28 6774 29989

Imperial Park, Newport
Gwent NP10 8ZY, UK.

t: +44 (0) 1633 657000
f: +44 (0) 1633 681864

e: info@quinn-group.com
w: www.quinn-group.com

